

V SAT

Ku-band VSAT

Model: **KU-100** Peripheral Equipment

Equipment List

Satellite Router	iDirect X5
Ethernet Switch	SRW2008
Option	
VoIP Switch	AFG200 (Up to two analog telephone connectable) AFG400 (Up to four analog telephone connectable) AFG800 (Up to eight analog telephone connectable)
19-inch Rack	RC-600V
UPS	E11A102A002USJ (200 V) or E11A102A001 (100 V)
Analog Telephone	FC755D1
Rack Mount Tray	iDirect 5100 tray

Satellite Router

iDirect X5 (with optional Rack mount tray)

4.7 kg 10.36 lb (iDirect X5: 1.8 kg 3.97 lb, Rack mount tray: 2.9 kg 6.39 lb)

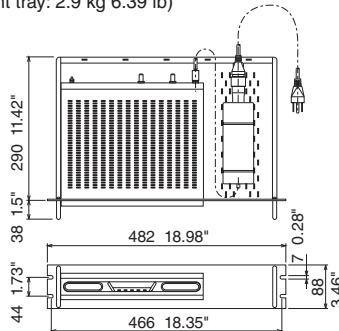

Ethernet Switch

SRW2008

1.0 kg 2.2 lb

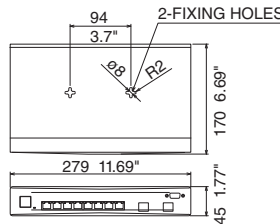

VoIP Switch

AFG200/400/800

0.6 kg 1.32 lb

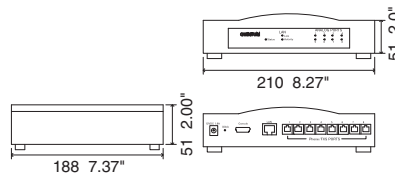

UPS

E11A102A002USJ/E11A102A001

17 kg 37.48 lb

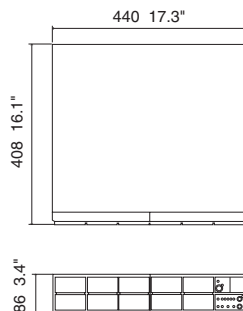

All brand and product names are registered trademarks, trademarks or service marks of their respective holders.
 SPECIFICATIONS SUBJECT TO CHANGE WITHOUT NOTICE

Satellite Router iDirect X5	
Networking	
Data Rate	DL 30 Msps (DVB-S2), 17 Msps (Infinity TDM)
	UL 7.5 Msps
Modulation	DL QPSK, 8PSK, 16APSK (DVBS2 mode) BPSK, QPSK, 8PSK (Infinity TDM)
	UL MF-TDM: BPSK, QPSK, 8PSK
Interface	Ethernet Switch (SRW2008) 8 ports (10 base-T/100 base-TX)
Power Supply	100-240 VAC: 4 A max, 50/60 Hz
Environment	
Temperature	0°C to +45°C
Relative Humidity	0 to 90 %
EMC	FCC Part 15 Class B, EN55022 Class B, CISPR 22 Class B, EN 61000-3-2, EN 61000-3-3, EN 55024, EN 301-489-1, EN 301-489-12, EN 61000-4-2/3/4/5/6/8, EN61000-4-11

Ethernet Switch SRW2008	
Power Supply	100-240 VAC, 50/60 Hz, 0.8 A max.
Environment	
Temperature	0°C to +40°C
Relative Humidity	10 to 90 %
EMC	FCC Part 15 Class A, EN 55022 Class A, EN 50082, EN 61000-6-1, EN 55024, EN 61000-3-2, EN 61000-3-3

VoIP Switch	AFG200	AFG400	AFG800
FXS ports	2	4	8
FXO ports	0	0	0
VoIP ports	2	4	8
Voice Algorithm	G.723.1a, G.729ab, G.711 Auto Codec negotiation		
FAX Support	T.38 (ITU-T) and G3 at 2.4, 4.8, 7.2, 9.6, 14.4 kbps		
Echo canceller	ITU Rec. G168, up to 128 ms		
IP option	DHCP Client		
Interface	RJ-11for analog telephone, 10/100 BASE-T RJ-45 LAN interface		
Power Supply	100-240VAC, 50/60 Hz, 22 W		

UPS	E11A102A002USJ	E11A102A001
System Topology	Hybrid	
Output Power	700 W/1000 VA	
Voltage	230 VAC	100 VAC
Frequency	50/60 Hz±8%	
Battery Type	Maintenance free sealed lead-acid battery	
Battery backup time	5 mins	
Environment		
Operating Temperature	0°C to +40°C	
Humidity	20 to 90 %	
EMC	EN 50091-2: 1995 Class A, EN 62040-1-1: 2003, EN 55091-1: 1995, EN 55022-1994/A1: 1995/A2: 1997, EN 55024-1998/A1: 2001/A2: 2003, EN 61000-4-2/3/4/5/6, EN 61000-4-11	

FURUNO ELECTRIC CO., LTD.
 Nishinomiya, Hyogo, Japan
 www.furuno.com
FURUNO U.S.A., INC.
 Camas, Washington, U.S.A.
 www.furunousa.com
FURUNO (UK) LIMITED
 Havant, Hampshire, U.K.
 www.furuno.co.uk
FURUNO NORGE A/S
 Ålesund, Norway
 www.furuno.no

FURUNO DANMARK A/S
 Hvidovre, Denmark
 www.furuno.dk
FURUNO SVERIGE AB
 Västra Frölunda, Sweden
 www.furuno.se
FURUNO FINLAND OY
 Espoo, Finland
 www.furuno.fi
FURUNO POLSKA Sp. z o.o.
 Gdynia, Poland
 www.furuno.pl

FURUNO DEUTSCHLAND GmbH
 Rellingen, Germany
 www.furuno.de
FURUNO FRANCE S.A.S.
 Bordeaux-Mérignac, France
 www.furuno.fr
FURUNO ESPAÑA S.A.
 Madrid, Spain
 www.furuno.es
FURUNO ITALIA S.r.l.
 Genoa, Italy

FURUNO HELLAS S.A.
 Glyfada, Greece
 www.furuno.gr
FURUNO (CYPRUS) LTD
 Limassol, Cyprus
 www.furuno.com.cy
FURUNO EURUS LLC
 St. Petersburg, Russian Federation
 www.furuno.com.ru
FURUNO SHANGHAI CO., LTD.
 Shanghai, China
 www.furuno.com/cn

FURUNO KOREA CO., LTD.
 Busan, Korea
RICO (PTE) LTD
 Singapore
 www.rico.com.sg